

A1	FUEL CONNECTION INLET. 550mm HOSE WITH SPHERICAL FITTING, ACC TO DIN 3863 (M18x1.5)
A2	FUEL CONNECTION OUTLET. 550mm HOSE WITH SPHERICAL FITTING, ACC TO DIN 3863 (M18x1.5)
A3	FUEL FILTER
A4	PRIMER PUMP
B1	OIL FILLER ENGINE
B2	OIL FILTER (2x)
B3	BYPASS OIL FILTER
B4	OIL DIPSTICK ENGINE
B5	OUTLET FOR OIL BILGE PUMP .12mm / 1/2 ID . HOSE PORT ALT. STARBOARD
B6	OIL DIPSTICK ENGINE(OPTION)
C1	FRESH WATER FILLER
C2	FRESH WATER DRAIN POINT (3x)
C3	CONNECTION HOT WATER INLET R 1/2" (OPTION)
C4	CONNECTION HOT WATER OUTLET R 1/2" (OPTION)
D1	SEA WATER INLET FOR $\phi$ 62/2.5" ID HOSE. CAN BE TURNED 360° (I.D. $\phi$ 52)
D2	SEA WATER DRAIN POINT (2x)
D3	WET EXHAUST CONNECTION $\phi$ 152mm/6" I.D HOSE (OPTION)
D4	DRY RISER. INCL WET EXHAUST CONNECTION (OPTION)
D5	EXHAUST DRY FLANGE DETAILS (OPTION)
E1	CONNECTION BATTERY POS. +
E2	CONNECTION BATTERY NEG. -
E3	ECU CONTROL UNIT
E4	AUXILIARY STOP
E5	DATALINK
E6	SENDERS
E7	AUX
E8	AUX
F1	AIR FILTER
G1	ELASTIC SUSPENSION (4x) (OPTION)
G2	LIFTING EYE (3x)
G3	ENGINE ANCHORAGE (2x) (OPTION)
H1	DIAGNOSE
H2	CONN. A
H3	CONN. B
J1	POWER STEERING PUMP (OPTION)
K1	TURBO FLANGE

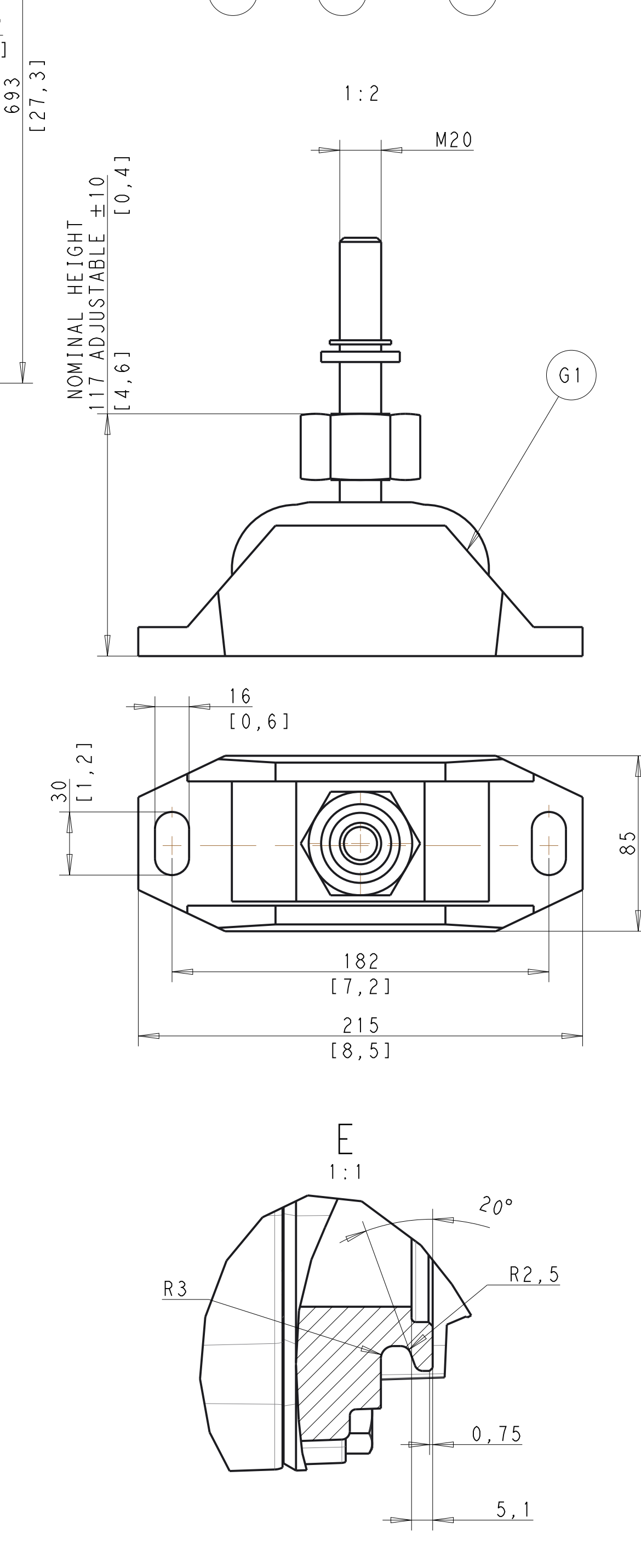
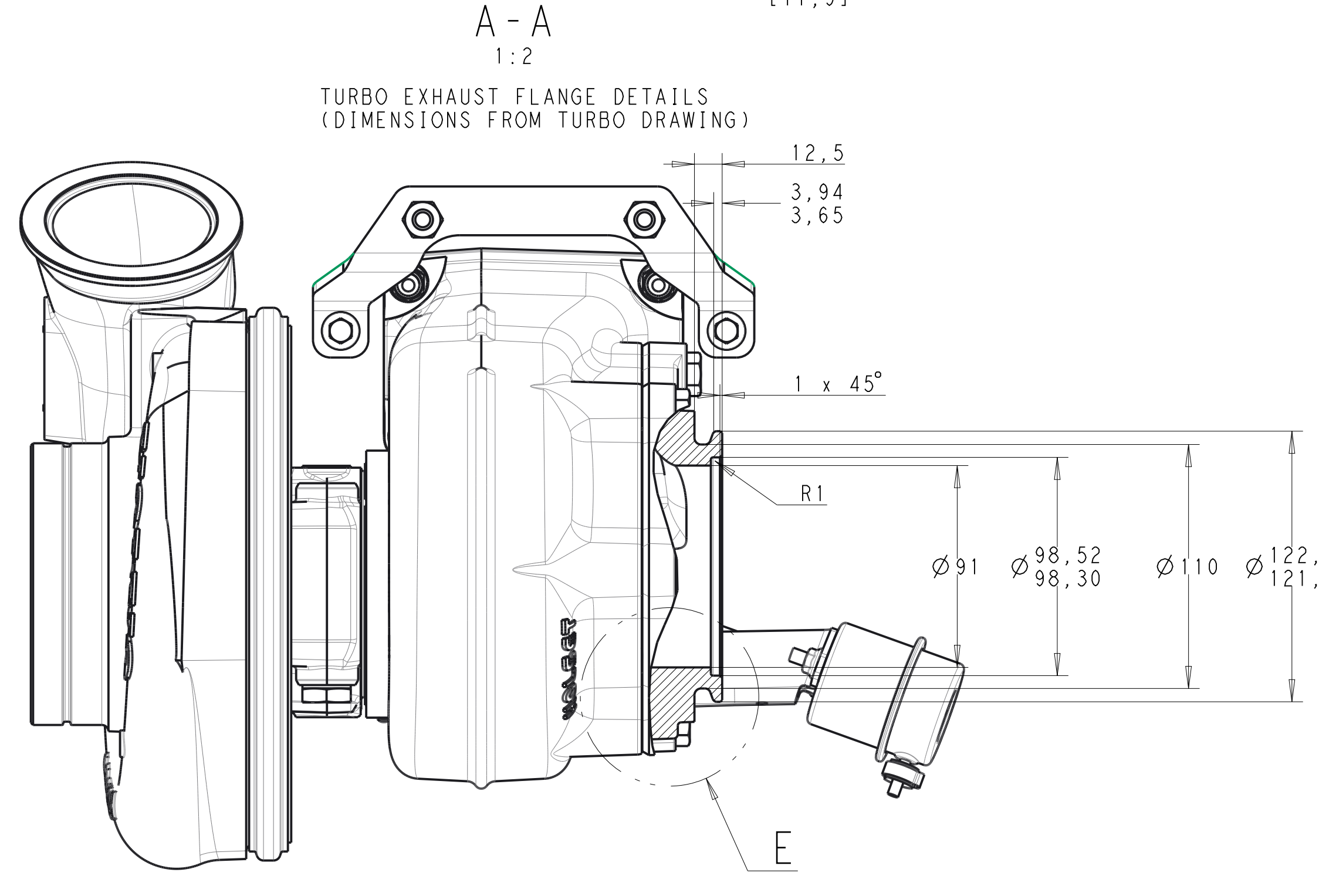
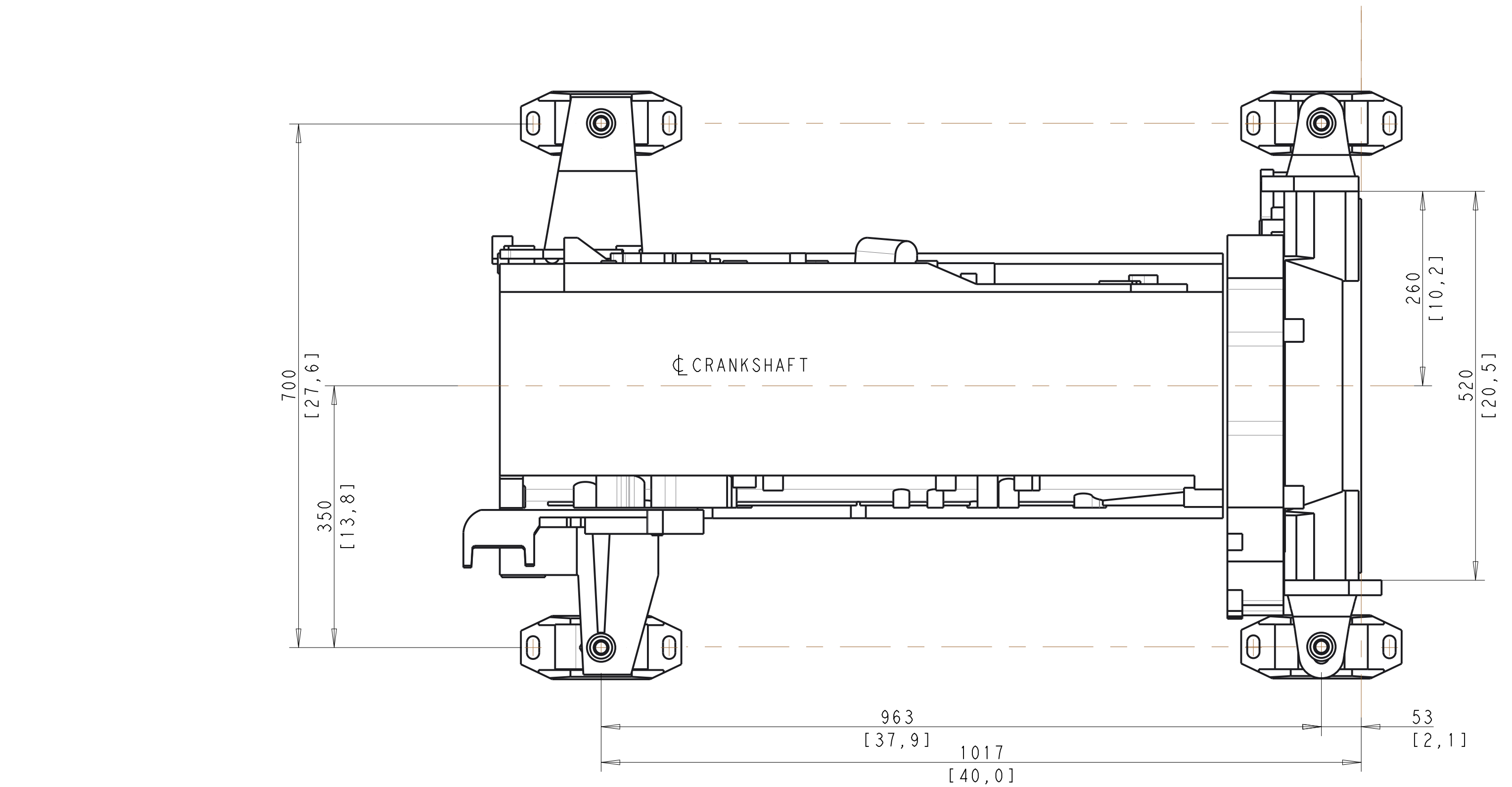

ALL EQUIPMENT ON THE DRAWING IS NOT STANDARD  
 FOR WEIGHT AND VOLUMES SEE TECHNICAL DATA SALES GUIDE  
 1) WATER LEVEL AT MAXIMUM REGULATED LOAD  
 SCALE 1:5

SYMBOLS, DESIGNATIONS AND GENERAL DRAWING METHODS STD 101-0005	
Drawing title: ENGINE DIMENSIONS	
D11 MARINE RG BOBTAIL	
STEP 5	
Drawing type: DIMENSION DRAWING	
Cover date: Document profile	
Document No: 22754397	Issue index: 03
Sheet No: 1(11)	SIZE: A

The copying, distribution and utilization of this document as well as the completion of its contents is allowed without special permission in principle. However, it is reserved to the extent of the patent validity model of trademark registration.