

**ECU UNIT**

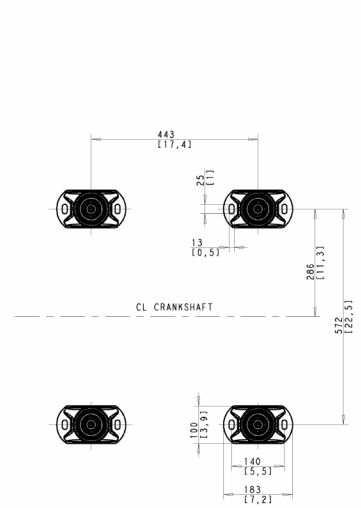
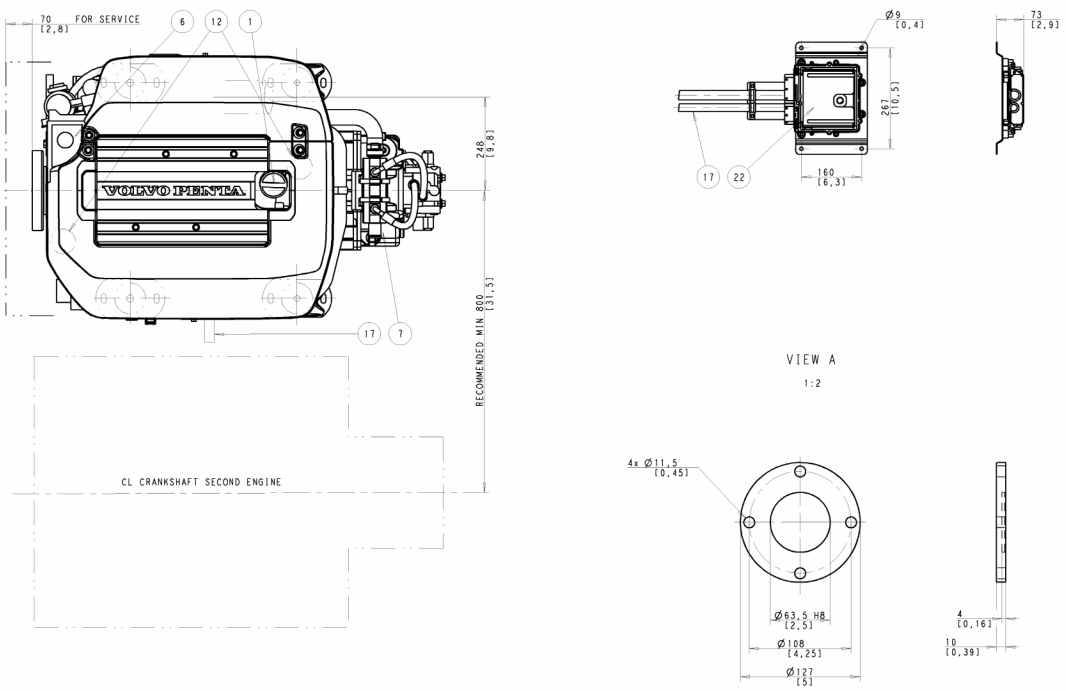

- 1 OIL FILLER CAP, ENGINE
- 2 OIL DIP STICK, ENGINE
- 3 OIL DRAIN (WITH PUMP), ENGINE
- 4 OIL FILTER
- 5 WATER DRAIN, FRESH WATER
- 6 WATER FILLER CAP FRESH WATER
- 7 WATER INLET, SEAWATER I.D. 32, 1.25"
- 8 WATER DRAIN CHARGE AIR COOLER, SEA WATER
- 9 WATER DRAIN HEAT EXCHANGER, SEAWATER
- 10 FUEL FILTER
- 11 AIR FILTER
- 12 LIFTING DEVICE 2x  $\varnothing 21$ , 0.83"
- 13 AUTOMATIC FUSE, VOLTAGE CONVERTER
- 14 EXHAUST ELBOW FOR HOSE I.D. 89, (3.5)
- 15 AUX. STOP
- 16 FUSE, FUEL FEED PUMP
- 17 ECU CABLE HARNESS L=1.5M (5 FEET)
- 18 CCV FILTER
- 19 FUEL INLET CONNECTION FOR HOSE I.D. 9,5 (3,8")
- 20 FUEL RETURN CONNECTION FOR HOSE I.D. 9,5 (3,8")
- 21 ECU UNIT (BULKHEAD MOUNTED)
- 22 OIL COOLER REVERSE GEAR

SCALE 1:5

**VOLVO PENTA**

INSTALLATION DRAWING  
 D3-MS45

21687603 02

THE COMPANY ASSUMES NO LIABILITY FOR THE CONTENTS OF THIS DRAWING.  
 ALL RIGHTS ARE RESERVED.  
 NO PART OF THIS DRAWING IS TO BE REPRODUCED OR TRANSMITTED IN ANY FORM OR BY ANY MEANS, WITHOUT THE WRITTEN PERMISSION OF THE COMPANY.  
 MADE IN SWEDEN