

- SCALE 1:5
ALL EQUIPMENT IS NOT STANDARD
CENTER OF GRAVITY
- A1 FLEX HOSE FUEL CON. IN. INTERNAL THREAD M18x1.5(DIN3863)
 - A2 FLEX HOSE FUEL CON. OUT. INTERNAL THREAD M18x1.5(DIN3863)
 - A3 FUEL FILTER
 - A4 PRIMER PUMP
 - A5 FUEL SHIFT VALVE
 - B1 OIL FILLER ENGINE
 - B2 OIL FILTER (2x)
 - B3 BYPASS OIL FILTER
 - B4 SHIFT VALVE
 - B5 OIL DIPSTICK ENGINE
 - B6 MANUAL OIL BILGE PUMP, 20mm I.D HOSE (OPTIONAL)
 - B7 CRANK CASE VENTILATION (OPTIONAL)
 - B8 OPEN CRANK CASE VENTILATION, 38MM
 - B9 OIL DRAINAGE
 - C1 FRESH WATER FILLER
 - C2 FRESH WATER FILLING (PRESURE CAP)
 - C3 FRESH WATER DRAIN POINT (6x)
 - C4 CONNECTION HOT WATER OUTLET R 1/2" (OPTION)
 - C5 CONNECTION HOT WATER INLET R 1/2" (OPTION)
 - C6 CONNECTION INLET ENGINE HEATER Ø29mm
 - C7 CONNECTION OUTLET ENGINE HEATER R 1/2"
 - D1 SEA WATER INLET Ø63 mm (2 1/2" I.D. HOSE)
 - D2 SEA WATER OUTLET Ø57 mm (2 1/4" I.D. HOSE) CAN BE TURNED 360°
 - E1 CONNECTION BATTERY POS. +
 - E2 CONNECTION BATTERY NEG. -
 - E3 ENGINE CONNECTION (8-POLES)
 - E4 SHUTDOWN CONNECTION, CONN. B (OPTIONAL)
 - E5 ENGINE CONNECTION, SHUTDOWN, CONN. A (8 POLES)(OPTIONAL)
 - E6 EMS CONTROL UNIT
 - E7 EMERGENCY STOP
 - F1 AIR FILTER
 - G1 FRONT LIFTING EYE (REMOVABLE) (1X)
 - G2 REAR LIFTING EYE (2X)
 - J1 FLEXIBLE COMPENSATOR EXHAUST SYSTEM 7" (OPTIONAL)
 - J2 REAR ENGINE BRACKETS(OPTIONAL)

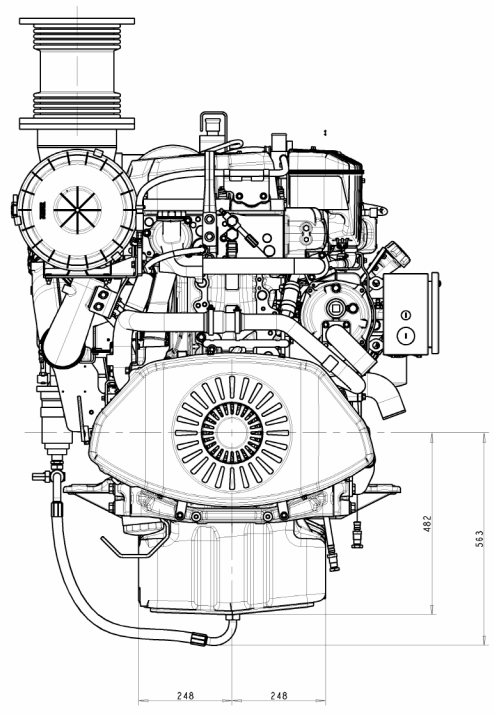
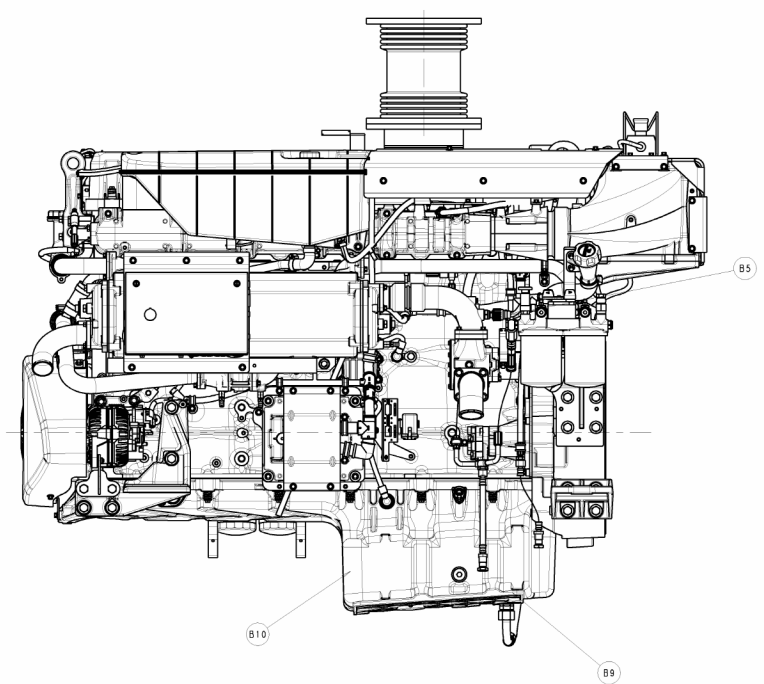

DATE	REVISION	DESCRIPTION	BY	DATE	REVISION	DESCRIPTION

SCALE 1:5
ALL EQUIPMENT IS NOT STANDARD

B5 OIL DIPSTICK ENGINE
B9 OIL DRAINAGE
B10 OIL PAN - 20898367 (OPTIONAL)

ENGINE DIMENSIONS	
DIEC-D MARINE BOBT, HE	
DIMENSION DRAWING	
22683477	01